

The families of HeartStation, Inc. would like to take this opportunity to thank-you for purchasing our product. We are proud of the construction and attention to detail you will find with our product. If this item does not meet your highest expectations, please contact us at 800.818.2939 and we will gladly accept your comments.

## What is the RescueCase?

The RescueCase is the first specifically designed cabinet to fit all Automated External Defibrillators (A.E.D.) models. This system allows for the end-user to bring their A.E.D. from storerooms and closets and place the defibrillator in a public space whereby ease of access is obtained and quicker defibrillation can be achieved.

The RescueCase accomplishes this goal by providing a secure, easily identifiable cabinet. It has been designed to be an **alerting system** to summon additional rescuers to the aid of a victim in which the use of the A.E.D. is indicated.

Its alerting system provides continual monitoring and sounds both visually and audibly when the door is opened for a rescue attempt. Additionally, by placing the unit into a constant public view, it reminds workers of its access for rescue when tragedy strikes.

Inspection of the A.E.D. can be made more frequently because the unit is in plain view at eye level. Also, the A.E.D.'s audible warning tone can be clearly heard outside of the case further allowing a quicker recognition for inspection by authorized individuals.

The RescueCase is an important link to guaranteeing that your customer's, employees and guests that frequent your place of business will receive quick and effective care through the use of your A.E.D. It also gives them the piece of mind that the A.E.D will be quicker to an emergency as the need arises.

# Installing Your RescueCase.....

## TOOLS NEEDED:

- ◆ Tape Measure
- ◆ Level
- ◆ Phillips Screw Driver
- ◆ Drywall Saw (Recessed Models)
- ◆ Utility Knife (Recessed Models)

### STEP 1:

Carefully inspect your RescueCase shipping container to ensure no damage has occurred upon arrival. Each RescueCase is carefully packed to guarantee its performance. Exterior damage to your RescueCase should be brought to the attention of the shipper.



### STEP 2:

Place your RescueCase on a flat surface. Carefully open the door so that the alarm cover is seen.

Remove the cover as shown in Figure 1-1.



### STEP 3:

Connect both 9 volt and 12 volt Lithium Battery with it's appropriate plug. See Figure 1-1.

Replace the alarm cover ***ensuring that all wires are not pinched.***

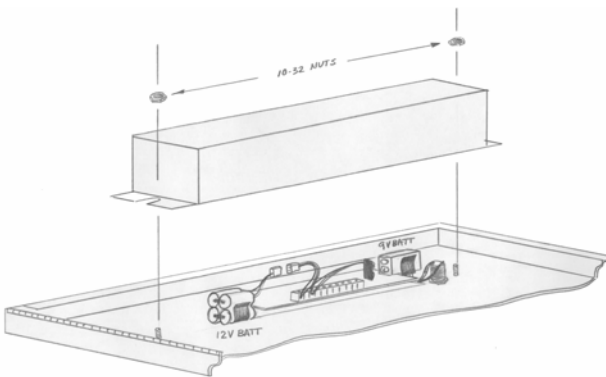

Figure 1-1.

### STEP 4:

Close door of the RescueCase completely.

### Test Alarm System:

Insert Alarm Key and Turn to "ON" position (Figure 1-2). Open Door —Alarm should sound for approximately **30Seconds**, followed by a Reminder Tone every **10 Seconds** thereafter.

If test is successful, proceed to Mounting of the RescueCase.



Figure 1-2.

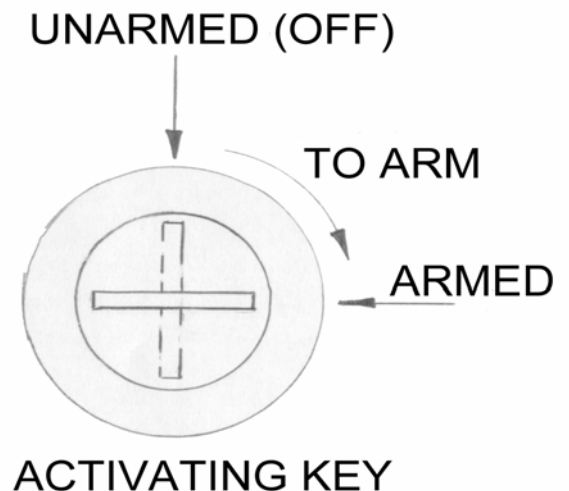

# Mounting Your RescueCase.....

## Model RC2000W

### STEP 1:

Locate the best area for RescueCase installation.

On typical frame construction, locate one stud to secure the RescueCase.

### STEP 2:

Measure from the floor up 42 inches. Draw a level line horizontally (see Figure 2-1).

### STEP 3:

Place the RescueCase on the line against the wall, confirming that the cabinet is level.

### STEP 4

Secure the case with the mounting screws provided\* (Figure 2-2 — next page).

Figure 2 - 1

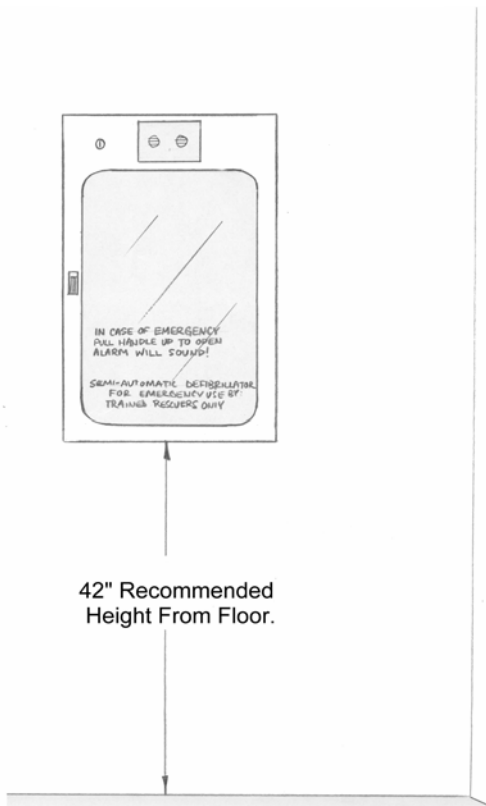
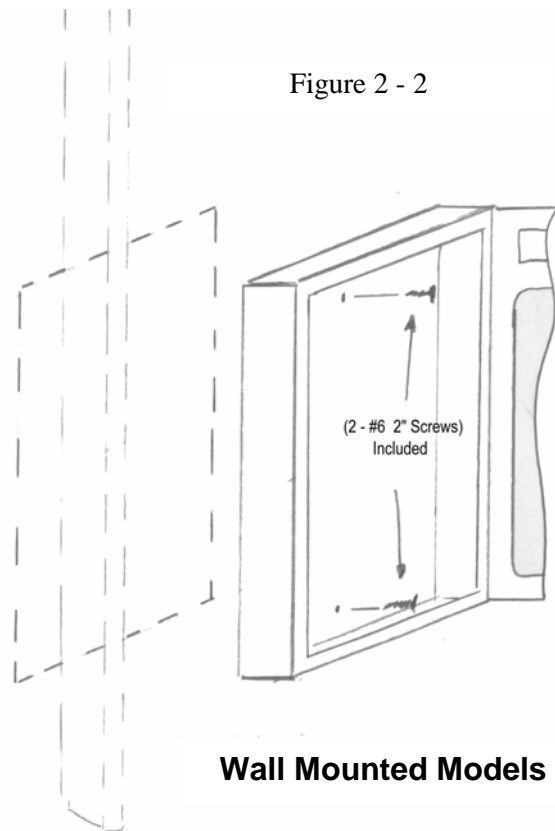

Figure 2 - 2



\*Note: Varying wall materials may require different mounting hardware — not provided.

**Wall Mounted Models**

# Mounting Your RescueCase.....

## Model RC2000R

### STEP 1:

Locate the best area for RescueCase installation.

On typical frame construction, locate the center between two studs to secure the RescueCase 42 inches from floor (see figure 2-1).

### STEP 2:

Measure from the floor up 42 inches. Draw a level line horizontally.

### STEP 3:

**RC2000R:** Cut out a rough opening for the RescueCase in the wall of **22 3/8"** high by **16 3/8"** wide.

See Figure 2-3.

### STEP 4:

Place the RescueCase inside the rough opening with the case outer flanges firmly against the exterior wall.

Ensure that the case is level inside of the opening.

### STEP 5:

Secure with four (4) screws (provided). Ensure that the door opens freely.

## **WARNING**

**BEFORE PROCEEDING, MAKE SURE NO ELECTRICAL, COMMUNICATION, PLUMBING OR HVAC SYSTEMS ARE WITHIN THE AREA OF MOUNTING!!**

Figure 2 - 3

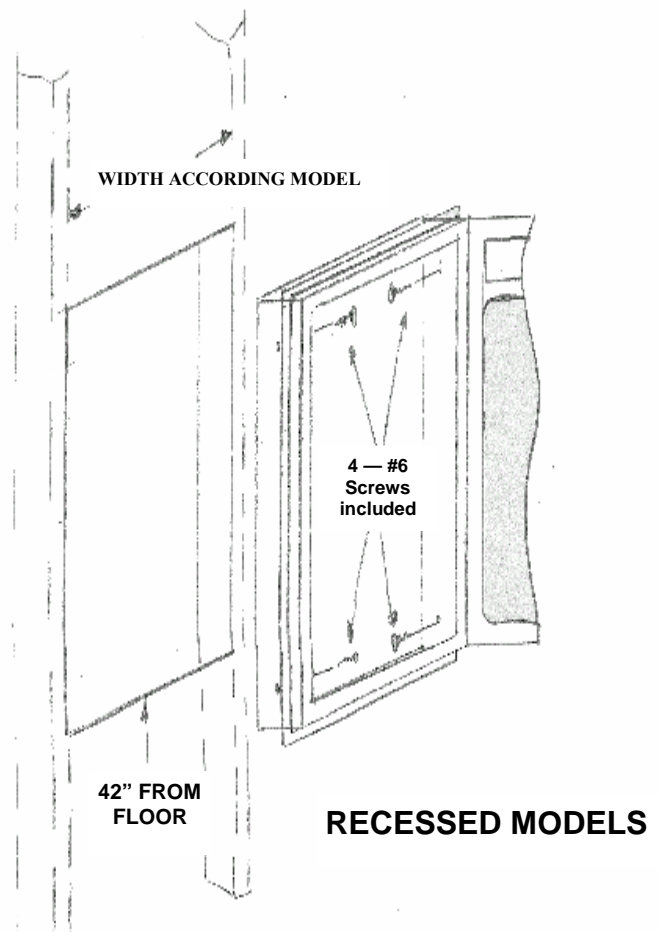

# Connecting to an Alarm Panel..... (optional feature - some models\*)

## STEP 1:

On Model RC2000W, prior to mounting the RescueCase, it is recommended that a "single gang" outlet box be located as shown in Figure 3 - 1.

On Model RC2000R, direct wiring to back of RescueCase is possible.

## STEP 2:

Pull the low voltage alarm wire (not provided) through the rear of the RescueCase next to the Terminal Block (See Figure 3 - 2).

Leave approximately five (5) inches of wire into the case.

Figure 3 - 2

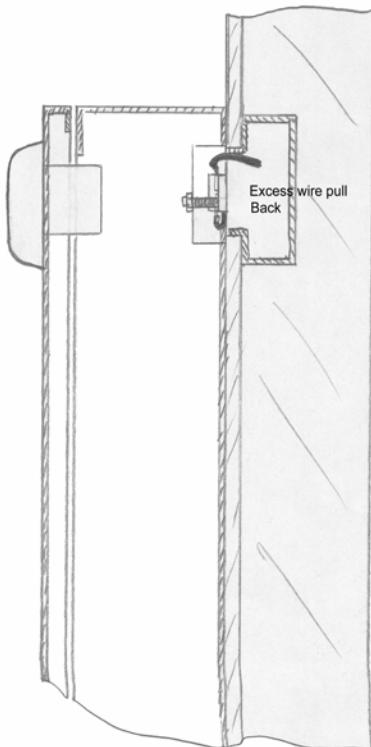
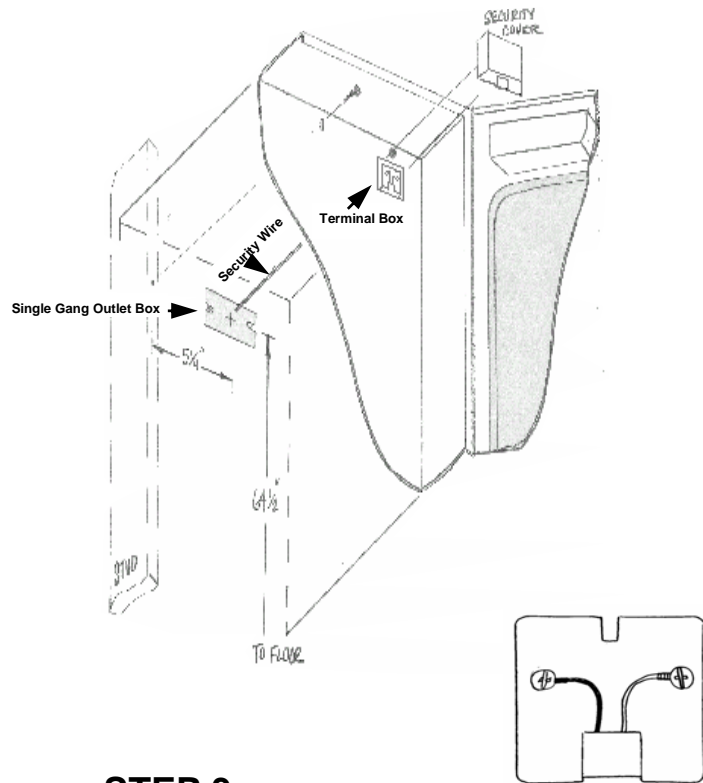

Figure 3 - 1



## STEP 3:

Mount the RescueCase as previously described.

## STEP 4:

Connect alarm wires to the appropriate terminal connection. Push excess wire out of case.

Test Alarm feature.

\*HeartStation recommends that this feature be installed by a trained alarm specialist.

# Maintaining Your RescueCase.....

## **CLEANING:**

The RescueCase has been carefully constructed to maintain a clean appearance. To help keep your RescueCase looking presentable, we advise that the only cleaning agents used on painted surfaces is a mild non-abrasive soap and water. For the plexi-glass area, a water/vinegar solution is recommended. If you are unsure of your cleaning agent, we recommend a test cleaning in a obscure area of the case.

## **BATTERY SYSTEMS:**

**9 Volt -** The battery does emit a low battery audible alarm when it needs to be changed. However, like any 9 volt battery used for notification, we recommend that the battery be changed with the change in Spring and Fall. Because of its function, we recommend that a good quality battery be used in its replacement. You may purchase batteries through us at: 800.818.2939.

**12 Volt -** The battery does not emit a low battery audible alarm when it needs to be changed. You may expect the 12 volt lithium battery to last between 3 to 5 years with infrequent use. It is however, based on the number of times the alarm is activated. Replacement batteries should be purchased directly through HeartStation, Inc. at 800.818.2939.

## **DOOR LATCH:**

From time to time, it may necessary to adjust the door latch to allow for a complete closing. Simply loosen the screws and nuts of the catch (on the inside box) and adjust accordingly and re-tighten.

## **SYSTEM TESTING:**

We recommend that a full test of the alarm is completed every six (6) months.

## **WHAT IF THE SYSTEM FAILS TO WORK?**

It probably involves a battery issue, replace the 9 volt battery first. If you still experience a problem, replace the 12 volt battery or contact us at: 800.818.2939. In all cases, remove and secure your A.E.D. until the system is functioning.

## **WHAT IF THE SIREN/LIGHT CONTINUES TO SOUND (WILL NOT STOP SOUNDING)?**

Disconnect both batteries immediately! Call us at 800.818.2939 for assistance. Remove and secure your A.E.D.

# **MANUFACTURERS LIMITED WARRANTY**

## **(Recessed and Surface Mounted Units)**

This agreement is by and between the equipment Owner, or Agent for the Owner, hereinafter called the "Owner" and HeartStation, Inc., hereinafter called "HeartStation" for these intended purposes.

placed within greatly reduces the longevity of the lithium batteries included in this system. HeartStation" is not responsible for any liabilities resulting as a result of battery failure. The "Owner" assumes responsibilities associated with maintaining battery systems.

### **LIMITED WARRANTY**

1. RescueCase is covered by a comprehensive one-year limited warranty against failure due to substandard material and workmanship, pursuant to which "HeartStation's" sole obligation shall be repair or replacement of such parts. This agreement does not include parts or service required as a result of damage by abuse, misuse, accident, fire, water, riot, vandalism, strikes, demonstrations, building collapse, Acts of God such as flood, earthquake, lightening, storm or unauthorized service or use of unauthorized parts.
2. RescueCase glass or plexi-glass surfaces are covered by this agreement for a period of one-year. This extends to fading, peeling, cracking or chipping of screened lettering on the plexi-glass surface. This agreement is void as a result of terms described prior as well as unauthorized cleaning agents.
3. Batteries are covered under the terms of this agreement for a period of three months. All batteries are fully tested and power levels are recorded prior to our shipping. Use of the RescueCase along with the environment that the case is

### **FUNCTIONS NOT INCLUDED**

4. "HeartStation" is not responsible for equipment not directly sold by "HeartStation". Automated External Defibrillators are covered by their existing warranties. "HeartStation" shall not be responsible, and "Owner" assumes all responsibility, for any personal injury, death, disfigurement or other court appointed damages arising out of the operation of the equipment. "Owner" agrees to indemnify, defend save "HeartStation" harmless from and against any and all claims, losses, damages, deaths or liabilities of any kind arising out of or in connection with any injury or damage to persons or property on or about "Owner" facility and the use of any A.E.D.
5. "HeartStation" is not responsible for theft of A.E.D. unit's .The RescueCase has been designed as an alerting device to summon assistance in cases of rescue attempts.

### **REGISTRATION**

The terms of this agreement become void if the "Registration For Limited Warranty Agreement" is not mailed within thirty days of purchase by "HeartStation" or its authorized distributor(s). The "Registration Card" activates the terms

**From the families of HeartStation, Inc.**

**WE THANK-YOU FOR THE OPPORTUNITY TO  
JOIN YOUR RESCUE TEAM AND LOOK**